

SPECIFICATION OF ROBOT

KF121EFE47
KF121EVE47

1st Edition : December.9.2011

KAWASAKI HEAVY INDUSTRIES LTD.
ROBOT DIV.

Doc, No: 90101-2044DEA

1. Specification of Robot (Floor and Ceiling mounted)

[1] Robot Arm															
1. Model	KF121E-D														
2. Type	Articulated Robot														
3. Degree of Freedom	6														
4. Motion Range & Max. Speed	Operating Axis	Motion Range	Max. Speed												
	Arm Rotation (JT1)	+160 ~ -160 °	220 °/s												
	Arm Out-in (JT2)	+90 ~ -90 °	120 °/s												
	Arm Up-down (JT3)	+150 ~ -150 °	240 °/s												
	Wrist Swivel (JT4)	+270 ~ -270 °	430 °/s												
	Wrist Bend (JT5)	+145 ~ -145 °	430 °/s												
	Wrist Twist (JT6)	+360 ~ -360 °	720 °/s												
5. Repeatability	±0.2 mm (at the tool mounting surface)														
6. Max. Payload	5 kg														
7. Max. Linear Speed	5000 mm/s (at the tool mounting surface) (Maximum Linear Interpolation Speed : 1500 mm/s)														
8. Load Capacity of Wrist	<table border="1"> <thead> <tr> <th></th> <th>Max. torque</th> <th>Moment of inertia*</th> </tr> </thead> <tbody> <tr> <td>JT4</td> <td>7.8 N·m</td> <td>0.17 kg·m²</td> </tr> <tr> <td>JT5</td> <td>7.8 N·m</td> <td>0.17 kg·m²</td> </tr> <tr> <td>JT6</td> <td>2.9 N·m</td> <td>0.06 kg·m²</td> </tr> </tbody> </table>				Max. torque	Moment of inertia*	JT4	7.8 N·m	0.17 kg·m ²	JT5	7.8 N·m	0.17 kg·m ²	JT6	2.9 N·m	0.06 kg·m ²
		Max. torque	Moment of inertia*												
JT4	7.8 N·m	0.17 kg·m ²													
JT5	7.8 N·m	0.17 kg·m ²													
JT6	2.9 N·m	0.06 kg·m ²													
<p>Note* Each value in this table shows allowable payload moment of inertia of JT4/JT5/JT6 when max. allowed torque is applied to each axis. If more detailed data is required for your application, please contact Kawasaki.</p>															
9. Driving Motor	Brushless AC Servomotor														
10. Working Envelope	Refer to Fig.1														
11. Mass	140 kg (excluding options)														
12. Color	White (Munsell:10GY9/1 equivalent)														
13. Installation	Floor and Ceiling mounted														
14. Environmental Condition	(Temperature) 0~40 °C (Humidity) 35~85 % No dew, nor frost allowed														
15. Explosion Proof	Pressurized and Intrinsically Safe														
16. Air Supply to the Robot	Clean & dry air: 0.3 Nm ³ /min, 0.3~0.7 Mpa														
	Dew point: -17 °C or less at atmospheric pressure. Solid material : 0.01 μm or less Oil content : Mist separation 99.9999% or more														
17. Option	Installation Base	Robot Pedestal 600 mm/300 mm Base Plate (750 mm x 750 mm)													
	Mechanical Stopper JT1														

Consult as about Maintenance Parts and Spare Parts.

1. Specification of Robot (Wall mounted)

[1] Robot Arm															
1. Model	KF121E-E														
2. Type	Articulated Robot														
3. Degree of Freedom	6														
4. Motion Range & Max. Speed	Operating Axis	Motion Range	Max. Speed												
	Arm Rotation (JT1)	+ 60 ~ - 60 °	120 °/s												
	Arm Out-in (JT2)	+ 90 ~ - 90 °	120 °/s												
	Arm Up-down (JT3)	+150 ~ - 150 °	240 °/s												
	Wrist Swivel (JT4)	+270 ~ - 270 °	430 °/s												
	Wrist Bend (JT5)	+145 ~ - 145 °	430 °/s												
	Wrist Twist (JT6)	+360 ~ - 360 °	720 °/s												
5. Repeatability	±0.2 mm (at the tool mounting surface)														
6. Max. Payload	5 kg														
7. Max. Linear Speed	3600 mm/s (at the tool mounting surface) (Maximum Linear Interpolation Speed : 1500 mm/s)														
8. Load Capacity of Wrist	<table border="1"> <thead> <tr> <th></th> <th>Max. torque</th> <th>Moment of inertia*</th> </tr> </thead> <tbody> <tr> <td>JT4</td> <td>7.8 N·m</td> <td>0.17 kg·m²</td> </tr> <tr> <td>JT5</td> <td>7.8 N·m</td> <td>0.17 kg·m²</td> </tr> <tr> <td>JT6</td> <td>2.9 N·m</td> <td>0.06 kg·m²</td> </tr> </tbody> </table>				Max. torque	Moment of inertia*	JT4	7.8 N·m	0.17 kg·m ²	JT5	7.8 N·m	0.17 kg·m ²	JT6	2.9 N·m	0.06 kg·m ²
		Max. torque	Moment of inertia*												
JT4	7.8 N·m	0.17 kg·m ²													
JT5	7.8 N·m	0.17 kg·m ²													
JT6	2.9 N·m	0.06 kg·m ²													
<p>Note* Each value in this table shows allowable payload moment of inertia of JT4/JT5/JT6 when max. allowed torque is applied to each axis. If more detailed data is required for your application, please contact Kawasaki.</p>															
9. Driving Motor	Brushless AC Servomotor														
10. Working Envelope	Refer to Fig.1														
11. Mass	140 kg (excluding options)														
12. Color	White (Munsell:10GY9/1 equivalent)														
13. Installation	Wall mounted														
14. Environmental Condition	(Temperature) 0~40 °C (Humidity) 35~85 % No dew, nor frost allowed														
15. Explosion Proof	Pressurized and Intrinsically Safe														
16. Air Supply to the Robot	Clean & dry air: 0.3 Nm ³ /min, 0.3~0.7 Mpa														
	Dew point: - 17 °C or less at atmospheric pressure. Solid material : 0.01 μm or less Oil content : Mist separation 99.9999% or more														
17. Option	Installation Base	Base Plate (750 mm x 750 mm)													
	Mechanical Stopper JT1														

Consult as about Maintenance Parts and Spare Parts.

[2] Controller		
1. Model	E45/E47	
2. Construction	Self-supported type	
3. Dimensions	See attached drawing	
4. Number of controlled axes	6 axes 7/8/9 axes(built-in addition, option)	
5. Servo control and drive system	Full Digital Servo System	
6. Type of control	Teach mode	Joint, Base, Tool, Fixed Tool (option) operation mode
	Repeat mode	PTP, CP control mode Joint, Linear, Circular (option) interpolation
7. Teaching method	Teaching or AS language programming	
8. Memory capacity	8 MB	
9. External operation signals	External Motor Power Off, External Hold, etc.	
10. General purpose signals	Input signals	32 channels (Includes dedicated signals)
	Output signals	32 channels (Includes dedicated signals)
11. Operation panel	Basic Operation Switches (Teach/Repeat SW, Emergency Stop SW, Control power lamp)	
12. Cable length	Power/Signal cable in non hazardous area	3 m
	Power/Signal cable in hazardous area	3 m
	Teach Pendant cable	10 m
13. Mass	See attached drawing	
14. Power requirement	AC 380 - 415 V \pm 10%, 50/60 Hz, 3 phases, Max 5.1 kVA(E47), Max 7.3 kVA(E45)	
15. Ground	PE (Standard for Robots) Leakage current: max. 10 mA	
16. Ambient temperature	0 - 45 °C	
17. Relative humidity	35 - 85 % (non-condensation)	
18. Color	Munsell: 10GY9/1 equivalent	
19. Teach Pendant	Intrinsically safe construction, Color display (7.2 inch LCD) with touch panel Emergency Stop, Teach Lock and Deadman Switches	
20. AC Outlet	AC 220 - 240V Outlet (depends on Primary input voltage)	
21. Motor brake release	Manual brake release switch	
22. Safety circuit	Category3; Performance Level = d (EN ISO 13849-1:2008)	
23. Options		
General purpose signals	Input signals	64/96/128 channels (Includes dedicated signals)
	Output signals	64/96/128 channels (Includes dedicated signals)
I/O connector	D-SUB 37pin(male,female) with cover	
Operation panel	Motor Power ON, Cycle start, RUN/HOLD, Error reset, Error lamp	
Power/Signal cable	in non hazardous area 5,7,10,15,20,25,30m	} Total length: max. 40 m
	in hazardous area 1,5,7,10,15m	
Teach Pendant cable	5m, 15m, 20m, 25m	} Total length: max. 50 m
Teach pendant Connector Box	in non hazardous area 3,5,7,10,15,20,25,30m in hazardous area 1,3,5,7,10,15,20,25,30m	
Power requirement	AC 380 - 415 V, AC 440 - 480 V, AC 515 V, AC 575 V \pm 10%, 50/60 Hz, 3 phases, Max 7.3 kVA(E45/E47)	
Auxiliary storage	USB memory	
PC cable	1.5 m, 3 m	
Teach Pendant option	Cable hook, connector for TP less	
Others	LED Light, Field BUS, Software PLC, Analog input/output, Conveyor Synchronization, Paint Equipment Control and so on	
24. Others	Consult Kawasaki about maintenance parts and spare parts.	

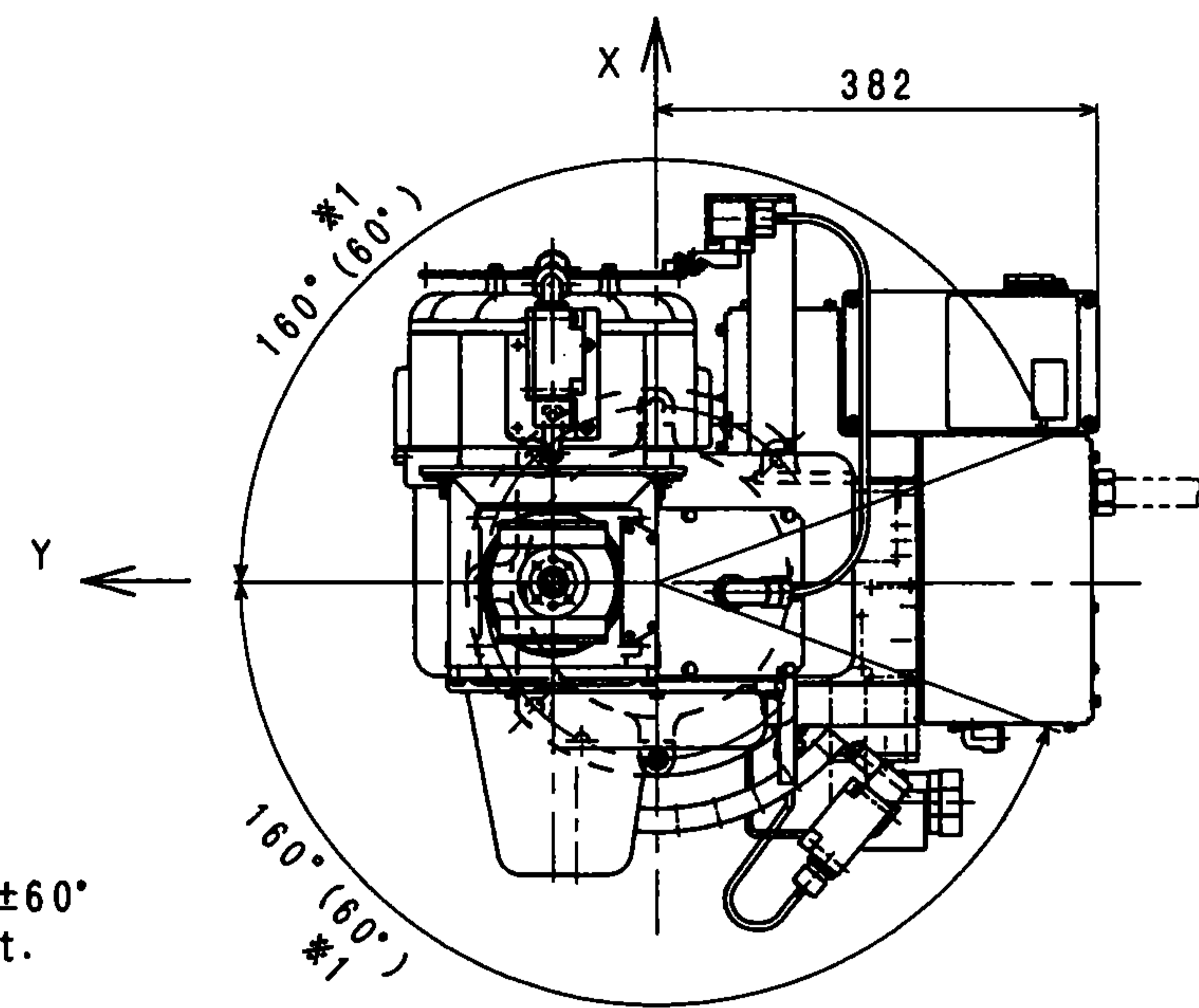

*1: JT1 motion range is $\pm 60^\circ$ in case of wall mount.

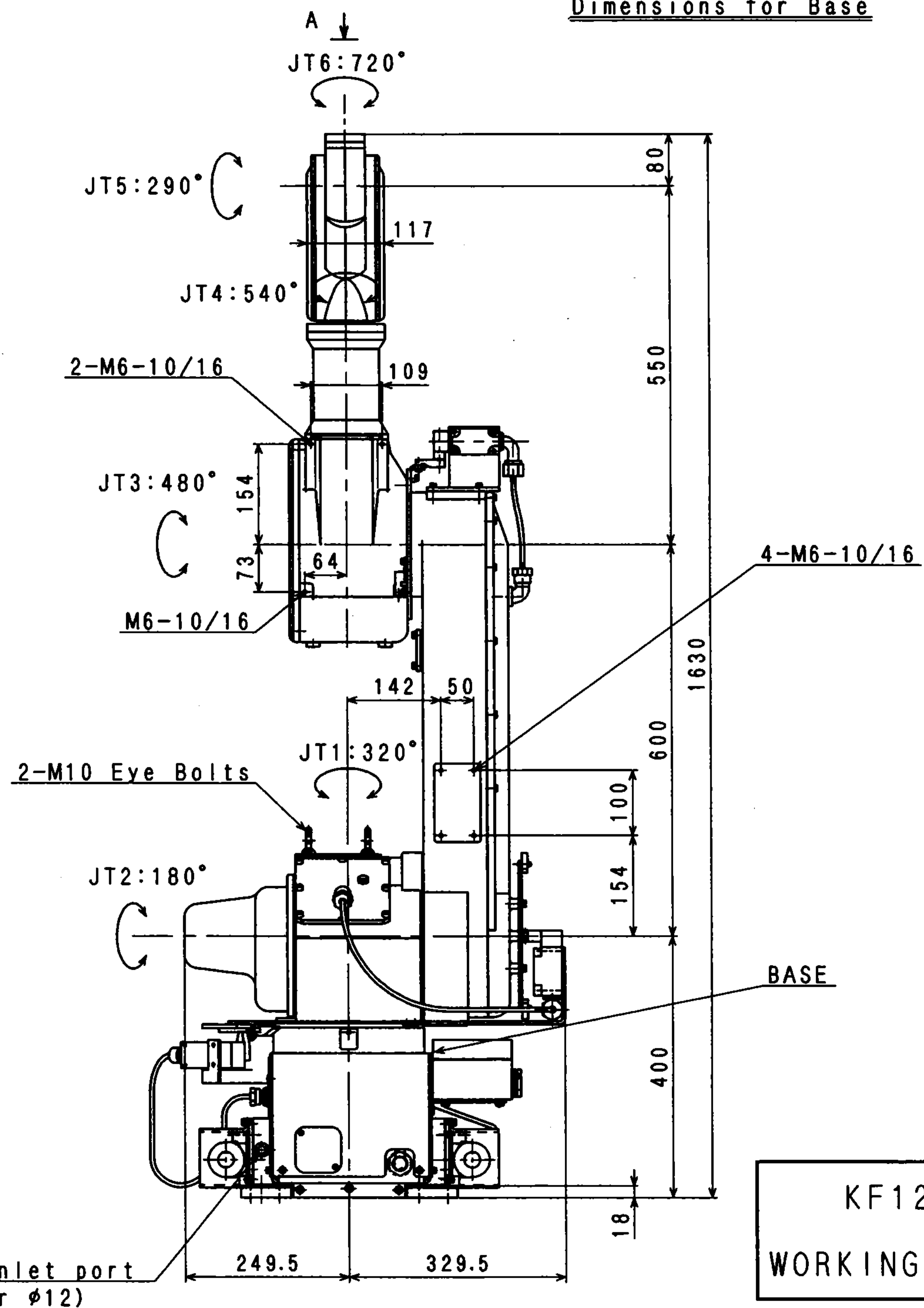
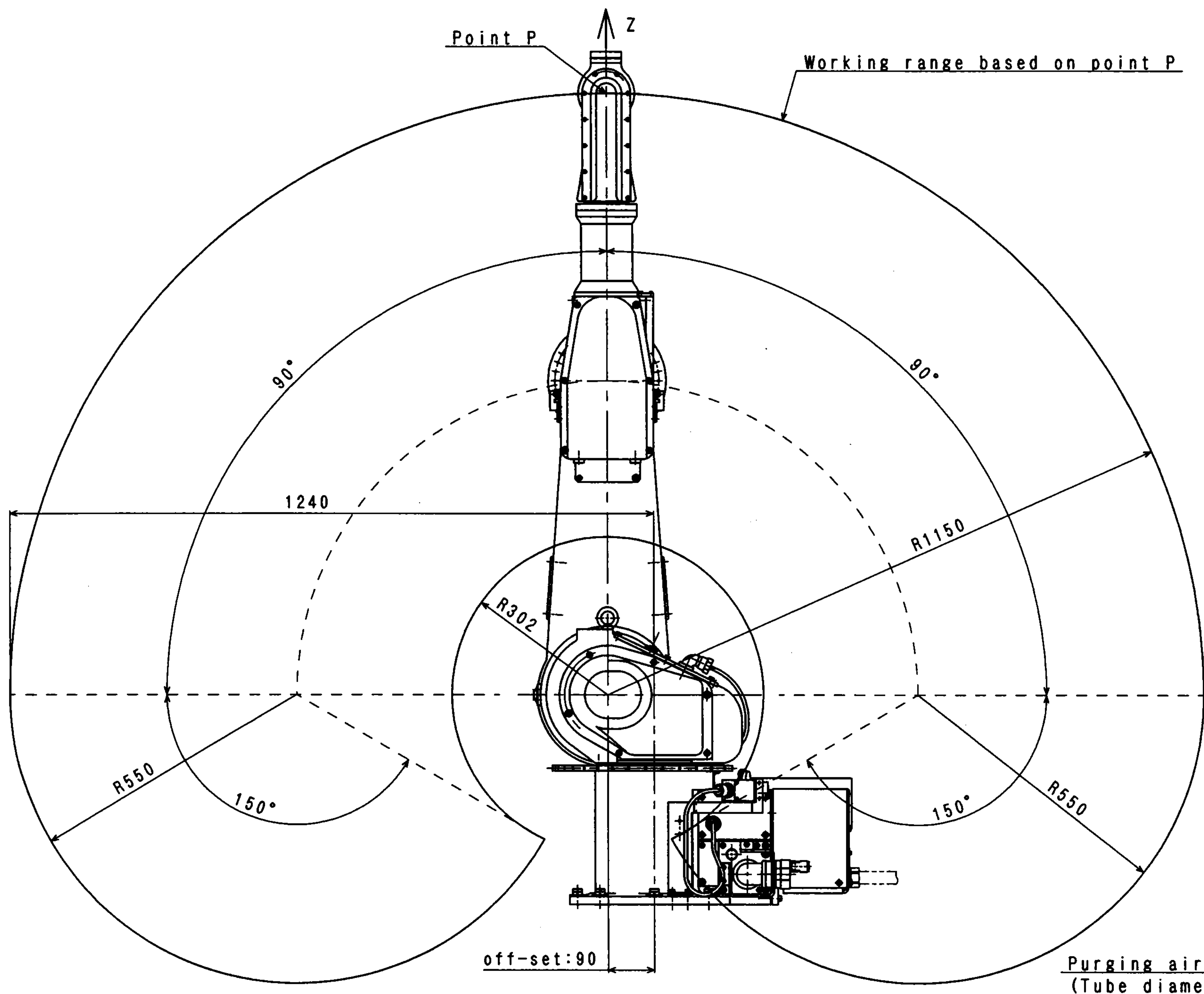
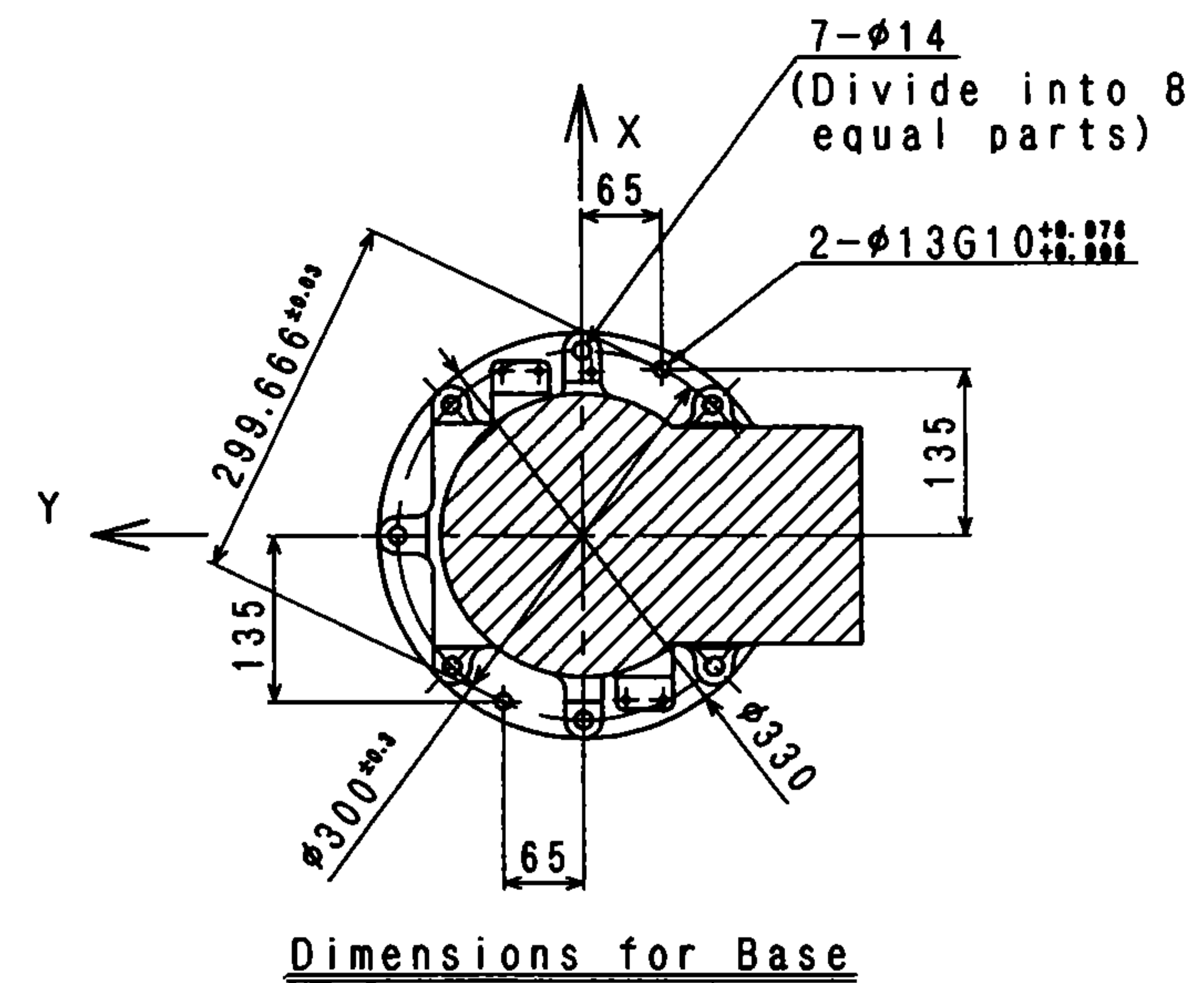
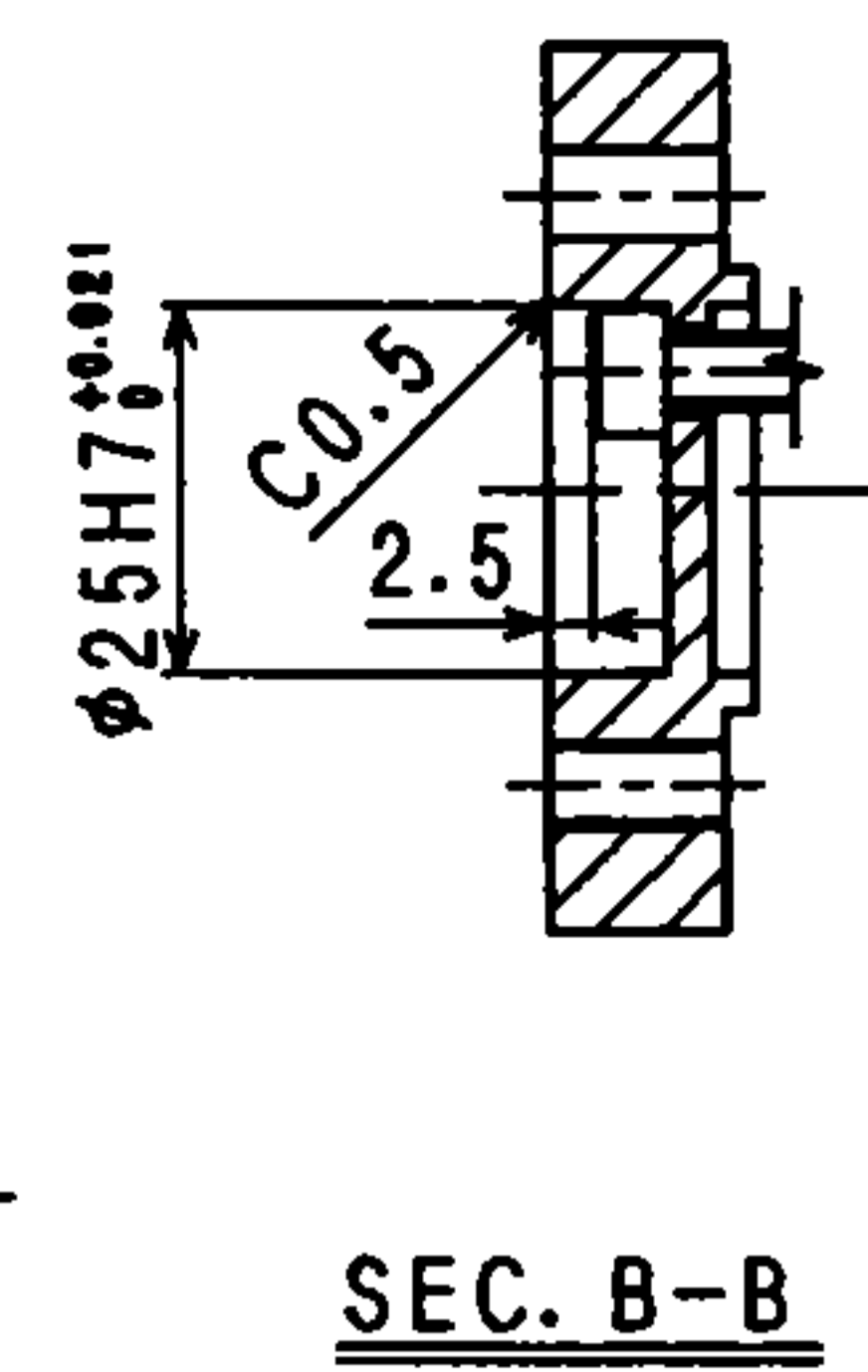
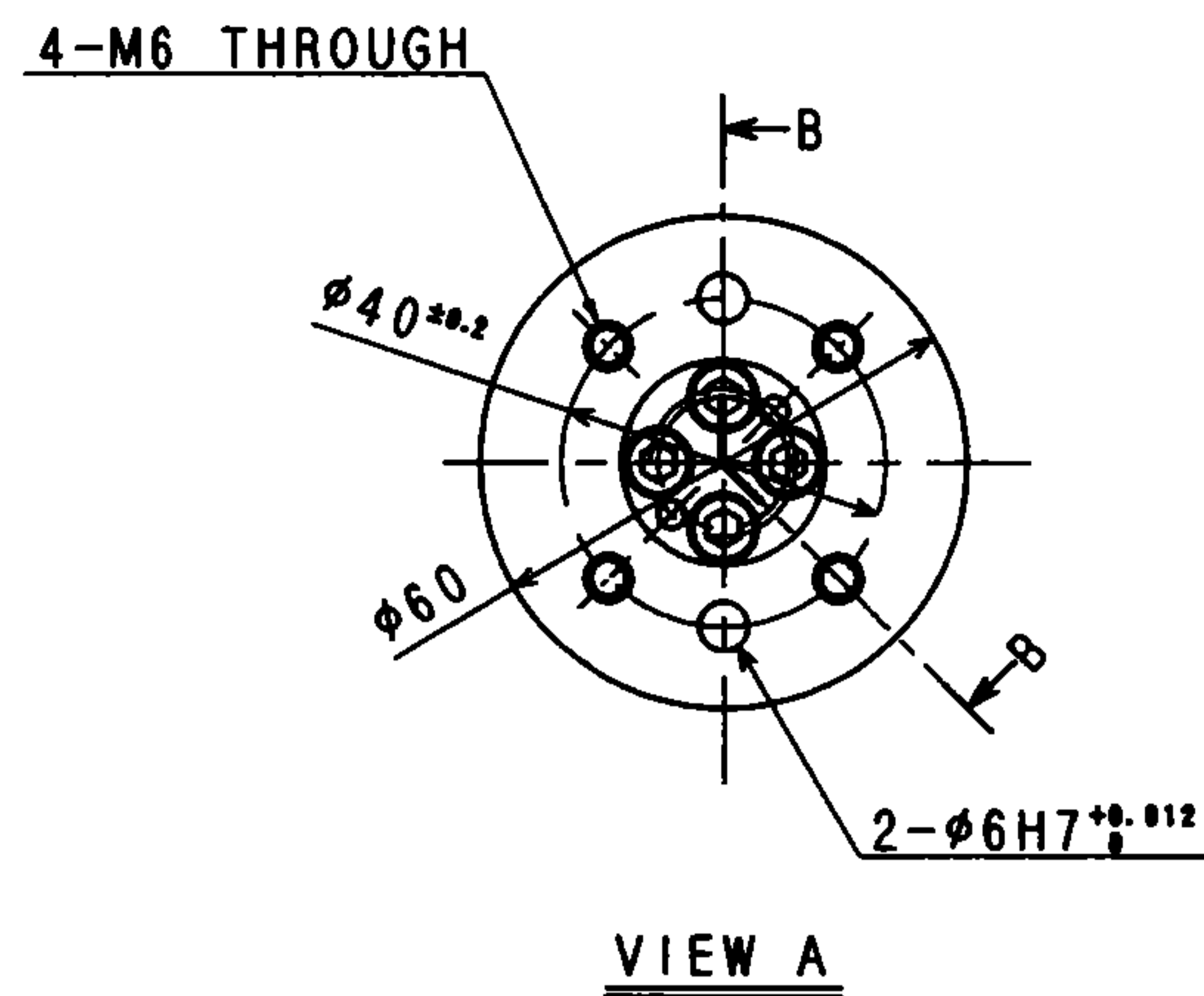

KF121E
WORKING RANGE

E 4 7 C O N T R O L L E R

M A S S : 1 7 0 K g

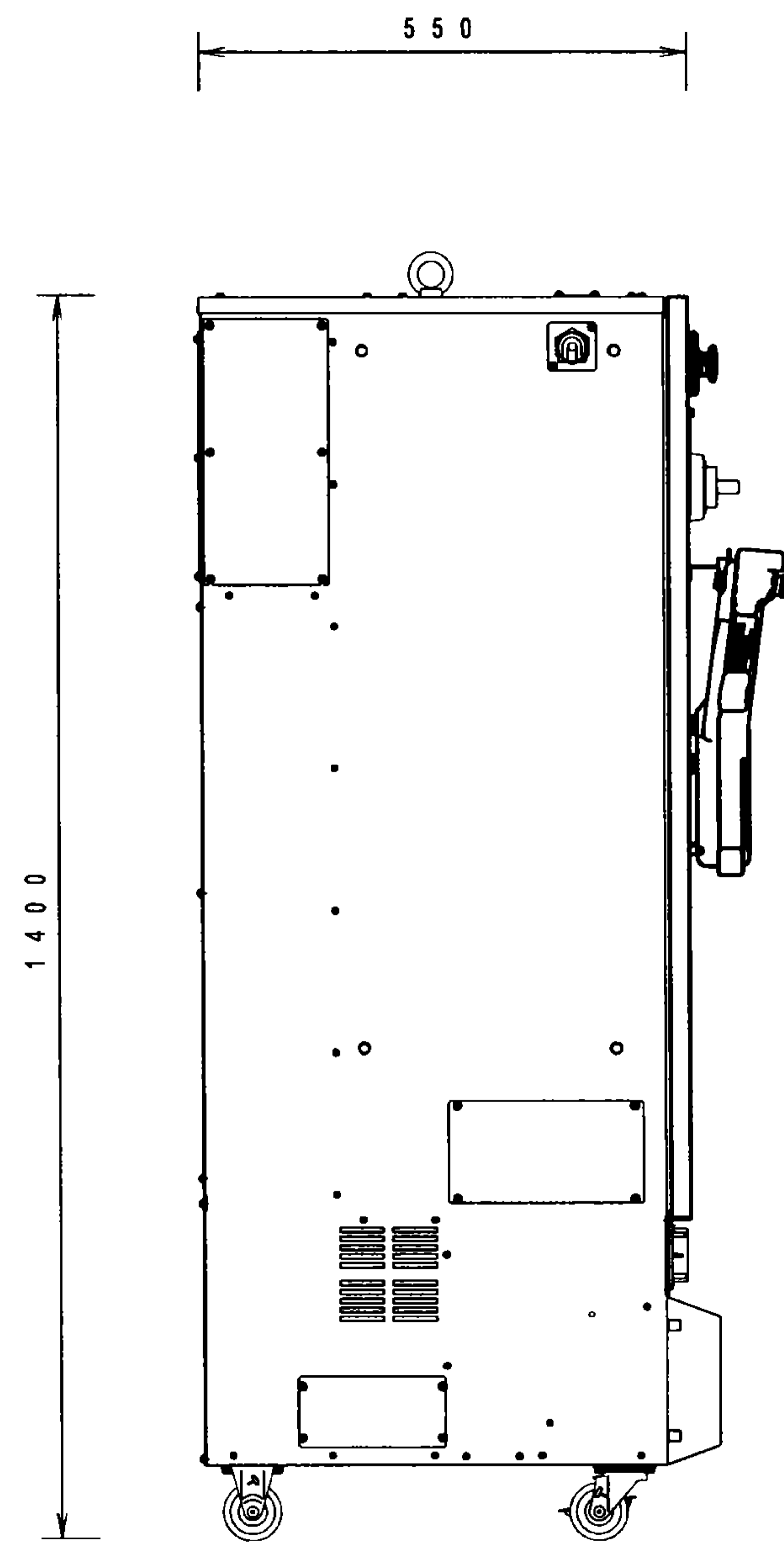

S I D E V I E W

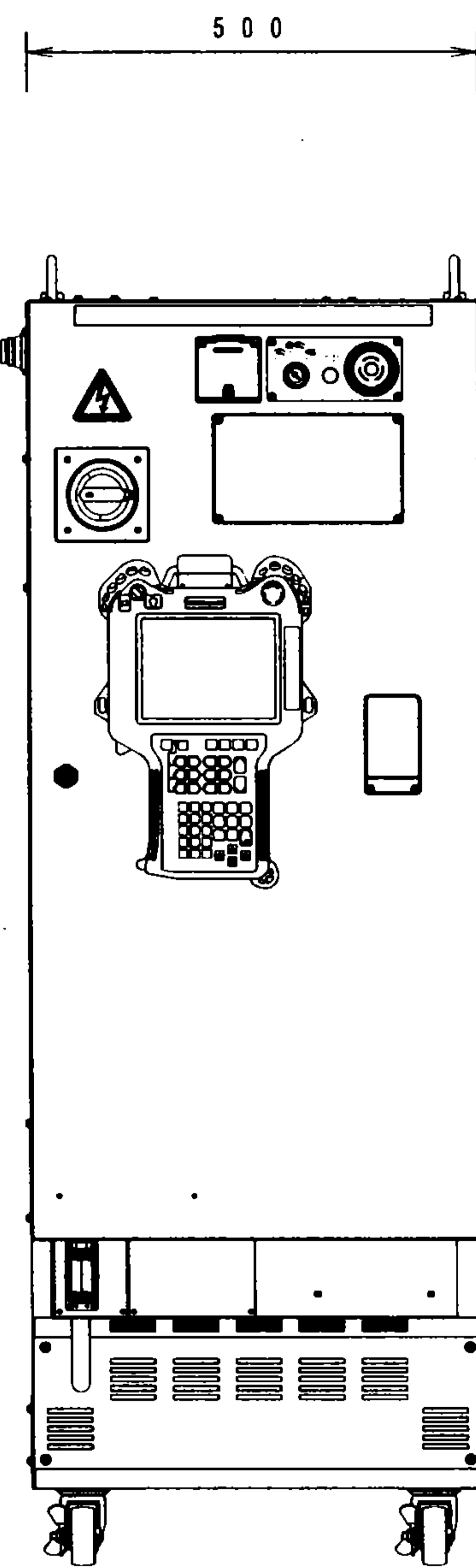

F R O N T V I E W

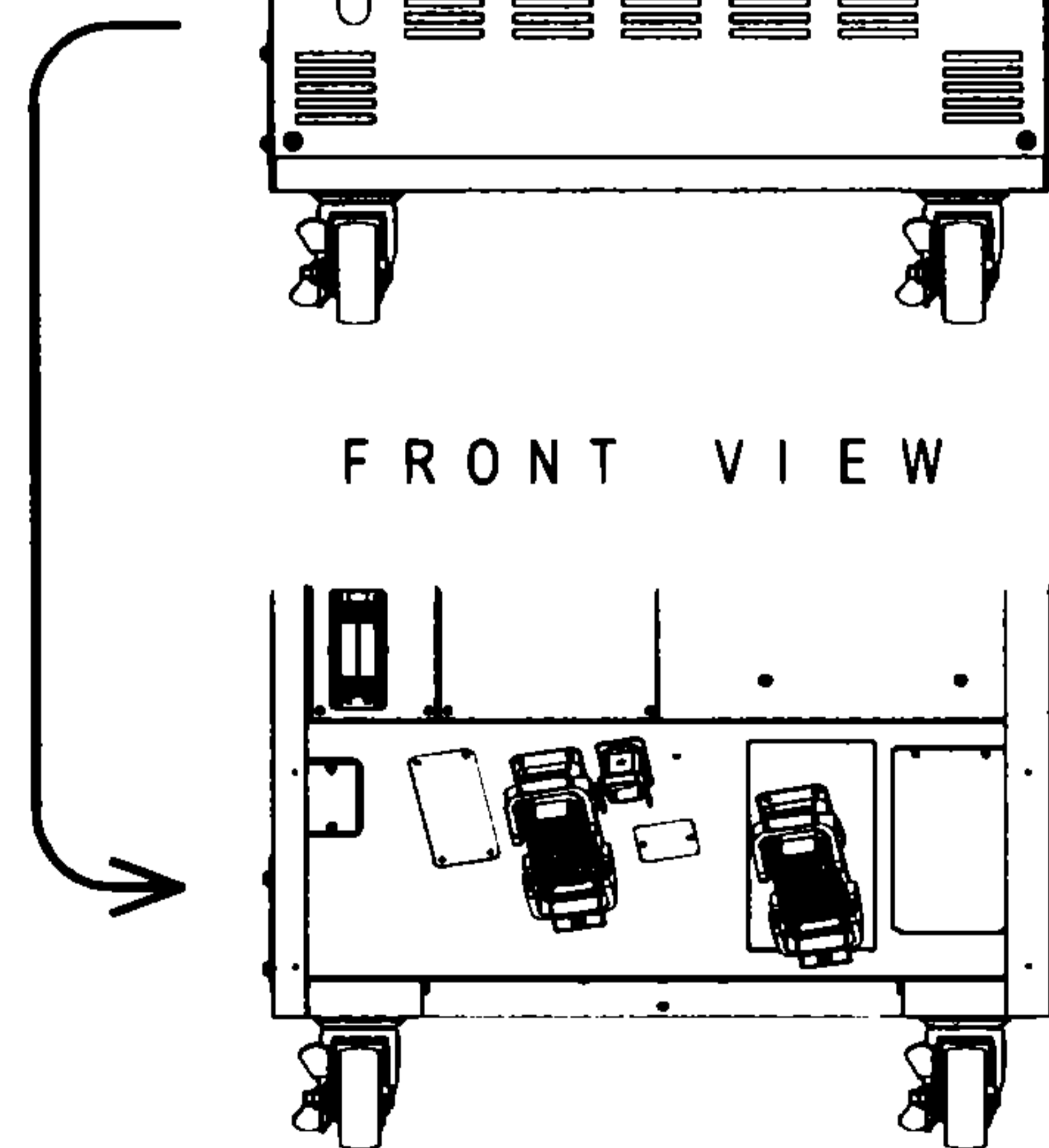

W I T H O U T C O N N E C T O R C O V E R

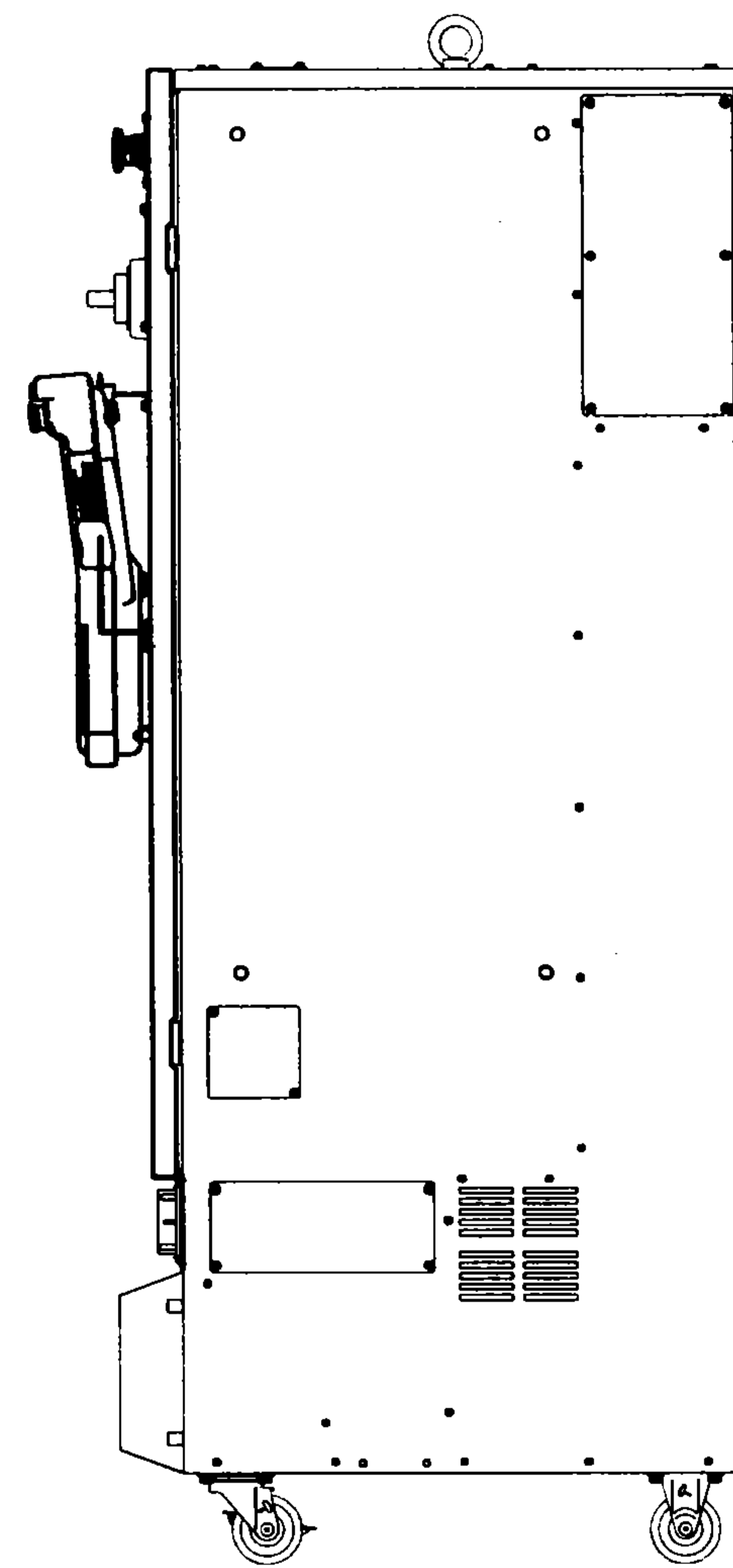

S I D E V I E W

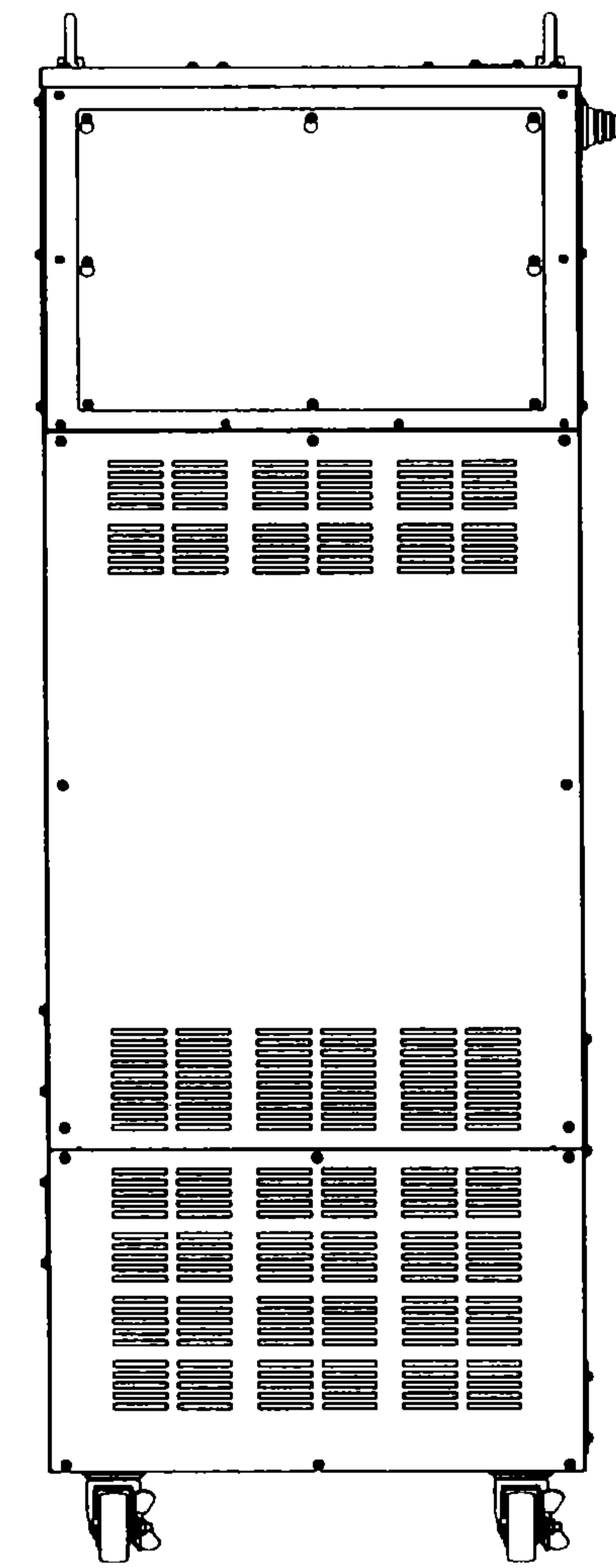

R E A R V I E W